

MC series modular check valves allow free flow in one direction and block flow in the counter direction.



Ordering details

MC	02	P	05	20
Sort	Nominal size	Pilot oil port	Kracking pressure	Design code
Modular check valve	02:NG6 Cetop3 03:NG10 Cetop5 04:NG16 Cetop7 06:NG22 Cetop8	P:P port A:A port B:B port T:T port	05:0.35bar 50:3.5bar	20

Technical specification

Model	MC-02	MC-03	MC-04	MC-06
Max.flow rate (l/min)	35	70	300	450
Working pressure (MPa)	25			
Weight(kgs)	1	2.5	4.8	10.5

Symbol list

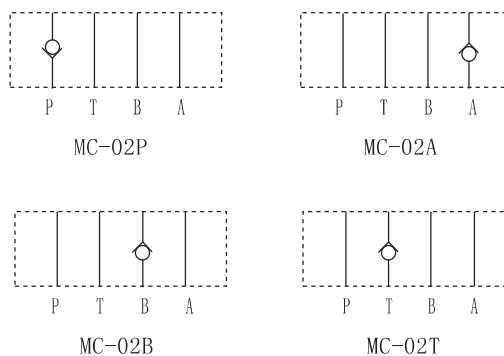

Dimensions

Unit: mm

MC-02P/T/B

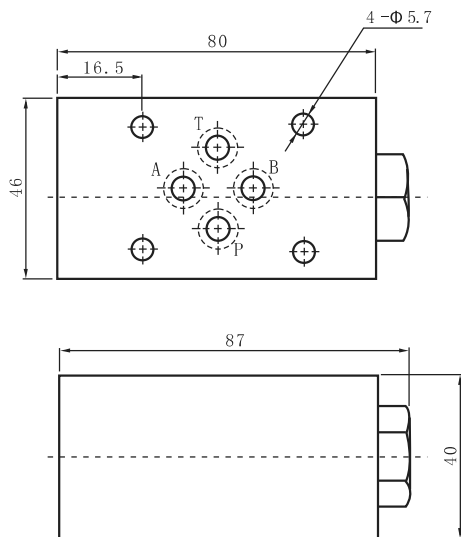

MC-02A

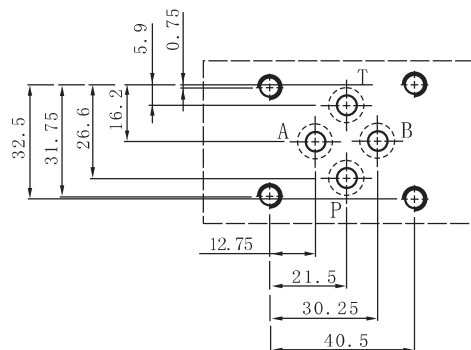
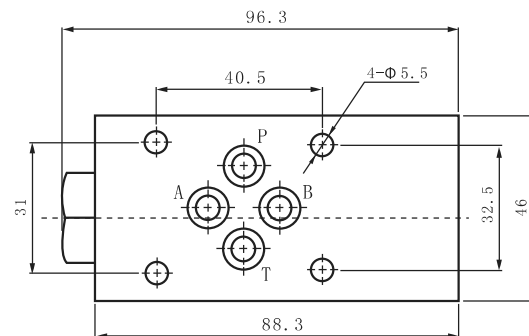
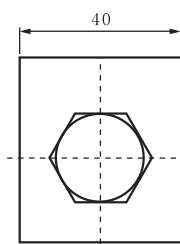

Dimensions

Unit: mm

MC-03A/B

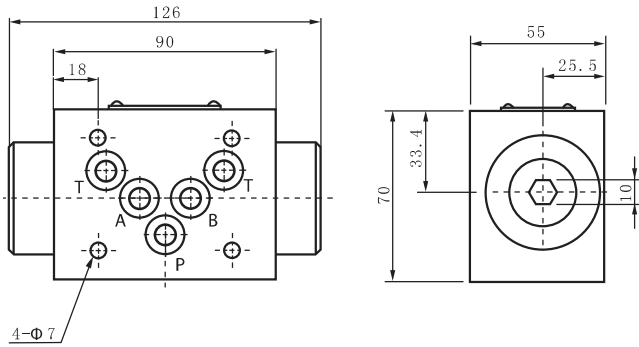

MC-03P/T

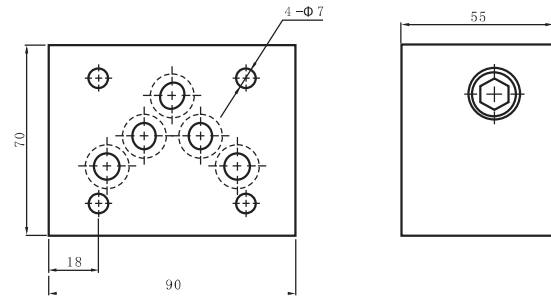

MC-04P

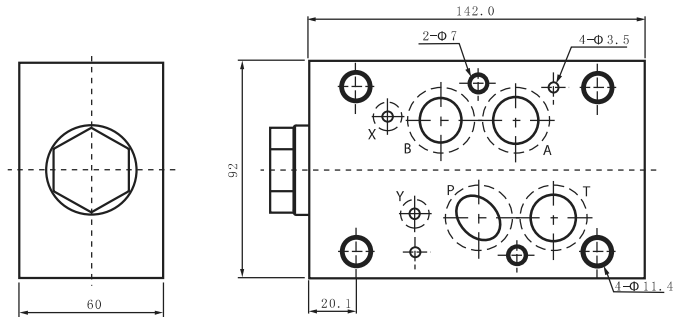

MC-06P/T

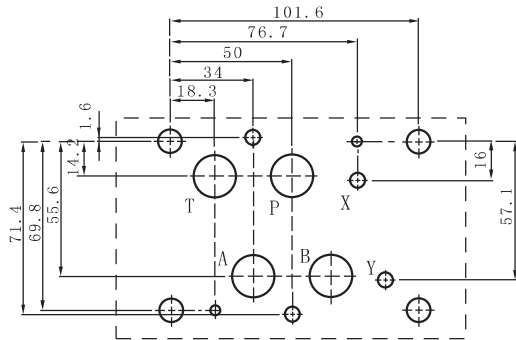
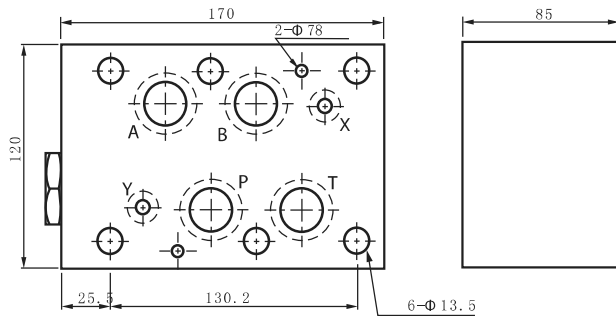

MC-06A/B

