



SW series solenoid check valves not only allow free flow in one direction and block flow in the counter direction, but also use pilot solenoid valve to control flow on-off and make flow in the counter direction viable.

Ordering details

SW	20	P	A	G24	Z4L
Sort	Nominal size	Mounting type	Standard solenoid	Input voltage	Connector type
Solenoid check valve	20:NG20 30:NG30	Suplate mounting	Standard solenoid	G12:DC12 G24:DC24 W220:AC220 W110:AC110 W220R:RAC220 W110R:RAC110	Z4: Standart plug-in connector Z4L: Plug-in connector with light

Technical specification

Model	SW20	SW30
Max. flow rate (l/min)	100	170
Working pressure (MPa)	31.5	
Weight(kgs)	5.5	9

Symbol

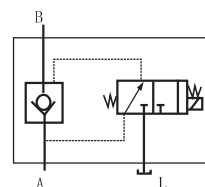

Dimensions

Unit: mm

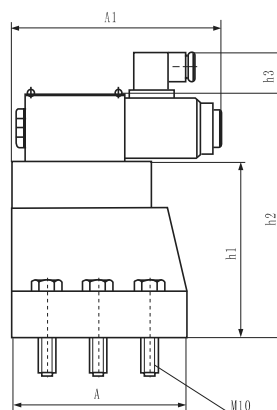
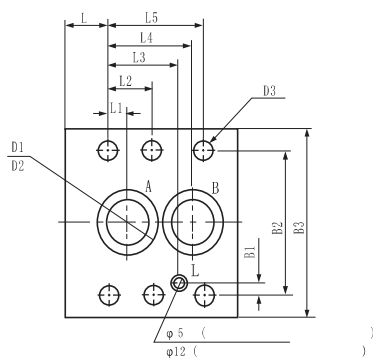

Model	L	L1	L2	L3	L4	L5	B1	B2	B3	D1	D2	D3	h2	A	h1	A1
SW20P	25	11.1	0	39.7	49.2	60.3	6.4	79.4	102	24	35	11	95	145	101	145
SW30P	27	16.7	42.1	59.5	67.5	84.2	3.8	96.8	120	32	41	11	118	160	122	145